

# LT81/LTM81-A

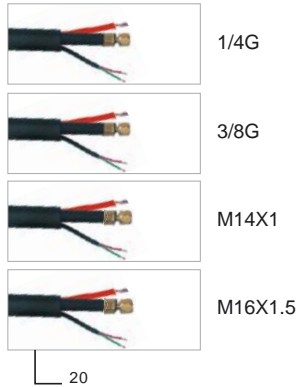

WITH HIGH FREQUENCY 高频

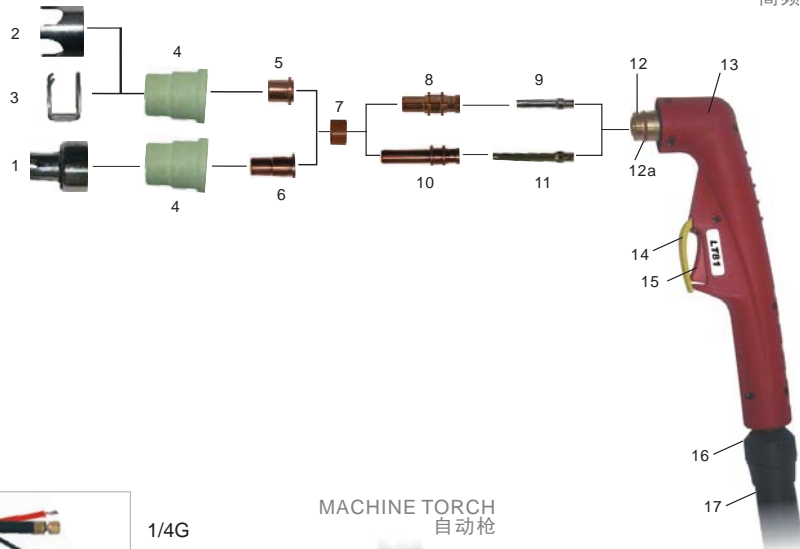

MACHINE TORCH 自动枪

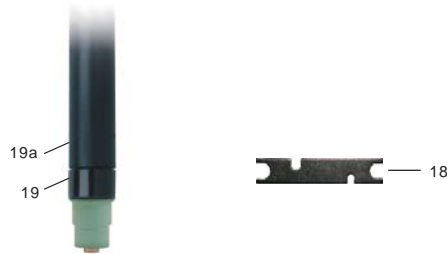

Technical Data 技术参数	
Current 额定电流	80 Amp
Duty Cycle 占载率	60%
Gas 气体	AIR 空气
Gas Pressure 气压	4.5-5.0 Bar
Gas Flow 气流量	160LPM
Ignition 引弧方式	HF 高频
Post Flow 气体延时	80 sec. recommended 推荐80秒
Standard Length 标准长度	6M

Link Welding Technology Co., Limited

Add: Rm. 19C, Lockhart Ctr., 301-307 Lockhart Rd., Wan Chai, Hong Kong.  
Tel: +00852-6735 8659 Fax: +00852-3114 9072 Email: info@linkwelding.com



HAND TORCH

Code	Ref	Description
IVT6900	PA1400	Plasma cutting torch LT81/6m 3/8G; 等离子切割枪/LT81/6m 3/8G
IVT6901		Plasma cutting torch LT81/6m M14x1; 等离子切割枪/LT81/6m/M14x1
IVT6905		Plasma cutting torch LT81/6m M16x1.5; 等离子切割枪/LT81/6m/M16x1.5
IVT6907	PA1402	Plasma cutting torch LT81/6m central adaptor; 等离子切割枪/LT81/6m/中央插头
IVT6909	PA1404	Plasma cutting torch LT81/6m 1/4G; 等离子切割枪/LT81/6m 1/4G

MACHINE TORCH

Code	Ref	Description
IVT0630		Plasma cutting auto torch LTM81/6m 3/8G; 等离子自动切割枪/LTM81/6m 3/8G
IVT0636		Plasma cutting auto torch LTM81/6m central adaptor; 等离子自动切割枪/LTM81/6m/中央插头
IVT0706		Plasma cutting auto torch LTM81/6m 1/4G; 等离子自动切割枪/LTM81/6m/1/4G
IVT0707		Plasma cutting auto torch LTM81/6m M16x1.5; 等离子自动切割枪/LTM81/6m/M16x1.5
IVT0708		Plasma cutting auto torch LTM81/6m M14x1; 等离子自动切割枪/LTM81/6m/M14x1

Position	Code	Ref	Description
1	ISM0706	CV0201	Spacer for contact cutting/LT81; 隔离支架/接触切割 LT81
2	ISM0088	CV0033	Four pointed spacer/LT81; 四点支架 LT81
3	ISM0073	CV0028	Spacer spring LT81; 隔离环 LT81
4			Outside nozzle; 外喷嘴
4.1	IVS0665-03	PC0115	Outside nozzle LT81; 外喷嘴 LT81
4.2	IVS0665-01		Outside nozzle/maximum life LT81; 外喷嘴/长寿命 LT81
5			Tip; 喷嘴
5.1	IVU0605-10	PD0105-10	Tip $\Phi$ 1.0mm LT81; 喷嘴 $\Phi$ 1.0mm/LT81
5.2	IVU0605-11	PD0105-11	Tip $\Phi$ 1.1mm LT81; 喷嘴 $\Phi$ 1.1mm/LT81
5.3	IVU0605-12	PD0105-12	Tip $\Phi$ 1.2mm LT81; 喷嘴 $\Phi$ 1.2mm/LT81
6			Tip; 喷嘴
6.1	IVU0601-10	PD0106-10	Extended tip $\Phi$ 1.0mm LT81; 加长喷嘴 $\Phi$ 1.0mm/LT81
6.2	IVU0601-12	PD0106-12	Extended tip $\Phi$ 1.2mm LT81; 加长喷嘴 $\Phi$ 1.2mm/LT81
7	IVF0602	PE0107	Diffuser LT81; 分流器 LT81
8	IVB0604	PR0109	Electrode Plasma LT81; 等离子电极 LT81
9	IVB0665	PR0115	Air tube/LT81; 导流管 LT81
10	IZN0510	FH0560	Extended electrode Plasma LT81; 加长等离子电极 LT81
11	IZN0516	FH0561	Extended air tube/LT81; 加长导流管 LT81
12	IVZ0690		Plasma torch head LT81; 等离子枪头 LT81
12a	IFT0675	EA0125	"O" ring $\Phi$ 15.6x1.78mm in silicon; O型圈 $\Phi$ 15.6x1.78mm/硅胶
13	IGV0035		Plasma handle manual/A Series/Red; 等离子手工手柄/A系列/红色
14	IHJ0722		Protection part/Plasma/Yellow; 开关保护档片/等离子用/黄色
15	IHQ0070	185.0031	Trigger; 开关
16	IHJ0893		Joint/small/new type; 球节套件/小/新式
17			Cable assembly; 电缆组
17.1	IVN00108066-00		CABLE ASSEMBLY/LT81/8MMQ/6M ATT. 1/8G; 电缆组/LT81/8MMQ/6M ATT. 1/8G
17.2	IVN00108060-00		CABLE ASSEMBLY/LT81/8MMQ/6M CENTER ADAPTOR; 电缆组/LT81/8MMQ/6M 中央插头
17.3	IVN10108066-00		CABLE ASSEMBLY/LTM81/8MMQ/6M ATT. 1/8G; 电缆组/LTM81/8MMQ/6M ATT. 1/8G
17.4	IVN10108060-00		CABLE ASSEMBLY/LTM81/8MMQ/6M CENTER ADAPTOR; 电缆组/LTM81/8MMQ/6M 中央插头
17.5	IVN0689		Cable assembly/LT81/6m central adaptor; 电缆组/LT81/6m/中央插头
18	ICG6006		Spanner for Plasma; 等离子枪扳手
19	IVZ0670	PF0120	Plasma torch head LTM81; 等离子枪头 LTM81
19a	IGV0018	WO300144	Fiber glass position tube/LTM; 自动枪手柄 LTM
20			Cable assembly LTM; 电缆组 LTM
20.1	IZT5687		Connecting adaptor 1/8G-1/4G; 转换接头1/8G-1/4G
20.2	IZT5686		Connecting adaptor 1/8G-3/8G; 转换接头1/8G-3/8G
20.3	IZT5688		Connecting adaptor 1/8G-M14x1; 转换接头1/8G-M14x1
20.4	IZT5689		Connecting adaptor 1/8G-M16x1.5; 转换接头1/8G-M16x1.5
21	IZX0078	FY0023	Central adaptor torch side Plasma 5 pins; 等离子中央插头/5针
22	ISM0056	CV0052	WHEEL SPACER A81/S75; 滚轮支架 A81/S75

Link Welding Technology Co., Limited

Add: Rm. 19C, Lockhart Ctr., 301-307 Lockhart Rd., Wan Chai, Hong Kong.  
Tel: +00852-6735 8659 Fax: +00852-3114 9072 Email: info@linkwelding.com