

LT151/LTM151-A

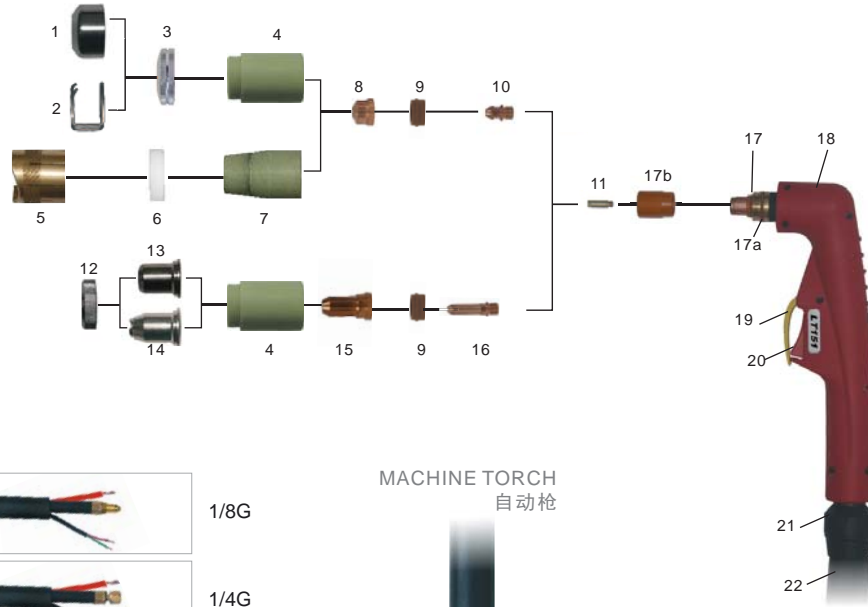

WITH HIGH FREQUENCY
高频



MACHINE TORCH
自动枪

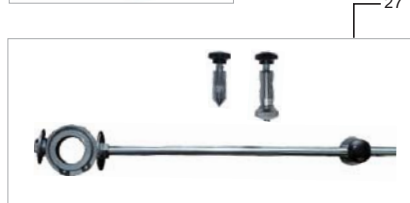

| Technical Data | 技术参数 |
|----------------------|----------------------------|
| Current 额定电流 | 150 Amp |
| Duty Cycle 占载率 | 60% |
| Gas 气体 | AIR 空气 |
| Gas Pressure 气压 | 4.5-5.0 Bar |
| Gas Flow 气流量 | 220LPM |
| Ignition 引弧方式 | HF 高频 |
| Post Flow 气体延时 | 150sec. recommended 推荐150秒 |
| Standard Length 标准长度 | 6M |

Link Welding Technology Co., Limited

Add: Rm. 19C, Lockhart Ctr., 301-307 Lockhart Rd., Wan Chai, Hong Kong.

Tel: +00852-6735 8659 Fax: +00852-3114 9072 Email: info@linkwelding.com



HAND TORCH

| Code | Ref | Description | Code | Ref | Description |
|---------|--------|---|---------|-----|---|
| IVT6550 | PA1550 | Plasma cutting torch LT151/6m M14x1; 等离子切割枪 LT151/6m M14x1 | IVT6556 | | Plasma cutting torch LT151/12m M14x1; 等离子切割枪 LT151/12m M14x1 |
| IVT6551 | | Plasma cutting torch LT151/6m 3/8G; 等离子切割枪 LT151/6m 3/8G | IVT6552 | | Plasma cutting torch LT151/12m 3/8G; 等离子切割枪 LT151/12m 3/8G |
| IVT6553 | | Plasma cutting torch LT151/6m M16x1.5; 等离子切割枪 LT151/6m M16x1.5 | IVT6554 | | Plasma cutting torch LT151/12m M16x1.5; 等离子切割枪 LT151/12m M16x1.5 |
| IVT6557 | | Plasma cutting torch LT151/6m 1/4G; 等离子切割枪 LT151/6m 1/4G | IVT6558 | | Plasma cutting torch LT151/12m 1/4G; 等离子切割枪 LT151/12m 1/4G |
| IVT6559 | PA1554 | Plasma cutting torch LT151/6m central adaptor; 等离子切割枪 LT151/6m 中央插头 | IVT6555 | | Plasma cutting torch LT151/12m central adaptor; 等离子切割枪 LT151/12m 中央插头 |

MACHINE TORCH

| Code | Ref | Description | Code | Ref | Description |
|---------|--------|---|---------|-----|---|
| IVT0759 | | Plasma cutting auto torch LTM151/6m 1/4G; 等离子自动切割枪 LT151/6m 1/4G | IVT0755 | | Plasma cutting auto torch LTM151/12m 1/4G; 等离子自动切割枪 LT151/12m 1/4G |
| IVT0751 | | Plasma cutting auto torch LTM151/6m 3/8G; 等离子自动切割枪 LT151/6m 3/8G | IVT0752 | | Plasma cutting auto torch LTM151/12m 3/8G; 等离子自动切割枪 LT151/12m 3/8G |
| IVT0672 | PA0127 | Plasma cutting auto torch LTM151/6m M14x1; 等离子自动切割枪 LT151/6m M14x1 | IVT0673 | | Plasma cutting auto torch LTM151/12m M14x1; 等离子自动切割枪 LT151/12m M14x1 |
| IVT0753 | | Plasma cutting auto torch LTM151/6m M16x1.5; 等离子自动切割枪 LT151/6m M16x1.5 | IVT0754 | | Plasma cutting auto torch LTM151/12m M16x1.5; 等离子自动切割枪 LT151/12m M16x1.5 |
| IVT0757 | | Plasma cutting auto torch LTM151/6m central adaptor; 等离子自动切割枪 LT151/6m 中央插头 | IVT0758 | | Plasma cutting auto torch LTM151/12m central adaptor; 等离子自动切割枪 LT151/12m 中央插头 |

| Position | Code | Ref | Description |
|----------|----------------|-----------|---|
| 1 | ISM0059 | | Gouging spacer/LT151; 弧口凿支架 LT151 |
| 2 | ISM0094 | | Spacer spring for ISM0093; 隔离环/配合 ISM0093 |
| 3 | ISM0093 | | Spring holder protection nut; 隔离环固定保护螺母 |
| 4 | IVS0686 | PC0131 | Outside nozzle LT141-151; 外喷嘴 LT141-151 |
| 5 | ISM6605 | CV1105 | Spacer/LT151; 隔离环/LT151 |
| 6 | IHJ0684 | | Nozzle shield/LT151; 外喷嘴保护帽/LT151 |
| 7 | IVS0670 | PC0120 | Outside nozzle LT151; 外喷嘴/LT151 |
| 8 | | | Tip; 喷嘴 |
| 8.1 | IVU0604-14 | PD0109-14 | Tip Φ 1.4mm LT151; 喷嘴 Φ 1.4mm/LT151 |
| 8.2 | IVU0604-16 | PD0109-16 | Tip Φ 1.6mm LT151; 喷嘴 Φ 1.6mm/LT151 |
| 8.3 | IVU0604-18 | PD0109-18 | Tip Φ 1.8mm LT151; 喷嘴 Φ 1.8mm/LT151 |
| 8.4 | IVU0604-30 | PD0109-30 | Tip Φ 3.0mm LT151; 喷嘴 Φ 3.0mm/LT151 |
| 9 | IVF0608 | PE0103 | Diffuser LT151; 分流器 LT151 |
| 10 | IVB0666 | PR0111 | Electrode Plasma LT151; 等离子电极 LT151 |
| 11 | IZN0768 | | Air tube/LT141-151; 导流管 LT141-151 |
| 12 | ISM0099 | | Locking nut; 锁紧螺母 |
| 13 | ISM0003 | CV0008 | Contact cutting attachment/LT100-151; 接触切割保护帽 LT100-151 |
| 14 | ISM0004 | CV0009 | Long contact cutting attachment/LT100-151; 长接触切割保护帽 LT100-151 |
| 15 | | | Tip; 喷嘴 |
| 15.1 | IVU0662-14 | PD0117-14 | Extended tip Φ 1.4mm/LT101-151; 加长喷嘴 Φ 1.4mm/LT101-151 |
| 15.2 | IVU0662-17 | PD0117-17 | Extended tip Φ 1.7mm/LT101-151; 加长喷嘴 Φ 1.7mm/LT101-151 |
| 15.3 | IVU0662-19 | PD0117-19 | Extended tip Φ 1.9mm/LT101-151; 加长喷嘴 Φ 1.9mm/LT101-151 |
| 15.4 | IVU0666 | PD0111 | Extended tip 50A/LT101-151; 加长喷嘴 50A/LT101-151 |
| 16 | IVB0661 | PR0116 | Extended electrode Plasma LT101-151; 加长等离子电极 LT101-151 |
| 17 | IVZ0610 | | Plasma torch head LT151; 等离子枪头 LTM151 |
| 17a | IFT0686 | EA0131 | "O" ring Φ 18.77 x 1.78mm in silicon; O型圈 Φ 18.77x1.78mm/硅胶 |
| 17b | IVF9007 | | Front insulator/LT141-151; 枪颈前端绝缘圈 LT141-151 |
| 18 | IGV0035 | | Plasma handle manual/A Series/Red; 等离子手柄/A系列/红色 |
| 19 | IHJ0722 | | Protection part/Plasma/Yellow; 开关保护档片/等离子用/黄色 |
| 20 | IHQ0070 | 185.0031 | Trigger; 开关 |
| 21 | IHJ0894 | | Joint/big/new type; 球节零件/大/新式 |
| 22 | | | Cable assembly; 电缆组 |
| 22.1 | IVN00316060-00 | | Cable assembly/LT141-151/16MQ/6M center adaptor; 电缆组/LT141-151/16MQ/6M 中央插头 |
| 22.2 | IVN00316066-00 | | Cable assembly/LT141-151/16MQ/6M ATT. 1/8G; 电缆组/LT141-151/16MQ/6M ATT. 1/8G |
| 22.3 | IVN10316060-00 | | Cable assembly/LTM141-151/16MQ/6M center adaptor; 电缆组/LTM141-151/16MQ/6M 中央插头 |
| 22.4 | IVN10316066-00 | | Cable assembly/LTM141-151/16MQ/6M ATT. 1/8G; 电缆组/LTM141-151/16MQ/6M ATT. 1/8G |
| 22.5 | IVN0699 | | Cable assembly/LT141-151/6m central adaptor; 电缆组/LT141-151/6m 中央插头 |
| 23 | ICG6006 | | Spanner for Plasma; 等离子枪扳手 |
| 24 | IVZ0666 | PF0111 | Plasma torch head LTM150; 等离子枪头 LTM151 |
| 24a | IGV0013 | | Fiber glass position tube/LTM; 自动枪手柄 LTM |
| 25 | | | Cable assembly LTM; 电缆组 LTM |
| 25.1 | I2T5687 | | Connecting adaptor 1/8G-1/4G; 转换接头 1/8G-1/4G |
| 25.2 | I2T5686 | | Connecting adaptor 1/8G-3/8G; 转换接头 1/8G-3/8G |
| 25.3 | I2T5688 | | Connecting adaptor 1/8G-M14x1; 转换接头 1/8G-M14x1 |
| 25.4 | I2T5689 | | Connecting adaptor 1/8G-M16x1.5; 转换接头 1/8G-M16x1.5 |
| 26 | I2X0078 | FY0023 | Central adaptor torch side Plasma 5 pins; 等离子中央插头 5针 |
| 27 | ISM0077 | CV0022 | Circle cutting attachment/LT100-151; 圆周切割附件 LT100-151 |

Link Welding Technology Co., Limited

Add: Rm. 19C, Lockhart Ctr., 301-307 Lockhart Rd., Wan Chai, Hong Kong.

Tel: +00852-6735 8659 Fax: +00852-3114 9072 Email: info@linkwelding.com